

[.06]
1.50

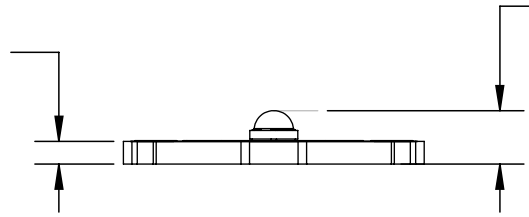

[.142]
[.138]
3.60
3.50

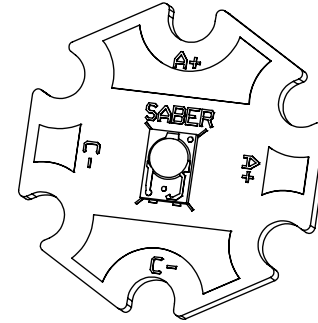

[.78]
19.90
[.37]
R9.50

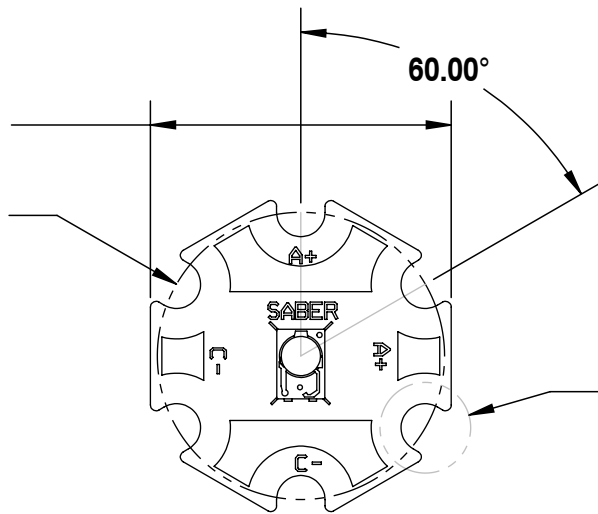

60.00°

[.24]
Ø6

[.13]
3.20

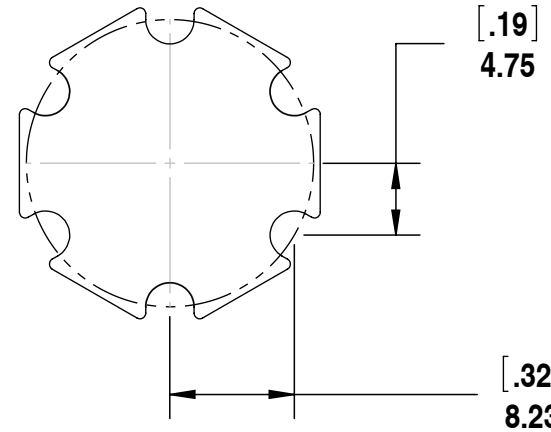
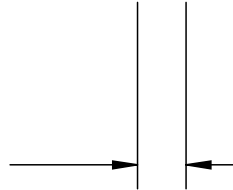

[.19]
4.75

[.32]
8.23

UNLESS OTHERWISE SPECIFIED:

DIMENSIONS ARE IN INCHES
TOLERANCES:
FRACTIONAL ±
ANGULAR: MACH ± BEND ±
TWO PLACE DECIMAL ±
THREE PLACE DECIMAL ±

INTERPRET GEOMETRIC
TOLERANCING PER:

MATERIAL

FINISH

DO NOT SCALE DRAWING

NAME

DATE

DRAWN

TW

4/23/2010

CHECKED

ENG APPR.

MFG APPR.

Q.A.

COMMENTS:

Quadica Developments Inc

TITLE:

Saber 20mm Star Base

SIZE
A

DWG. NO.

REV

SHEET 1 OF 1